

INSTALLATION INSTRUCTIONS FOR SINGLE CYLINDER DEADBOLTS

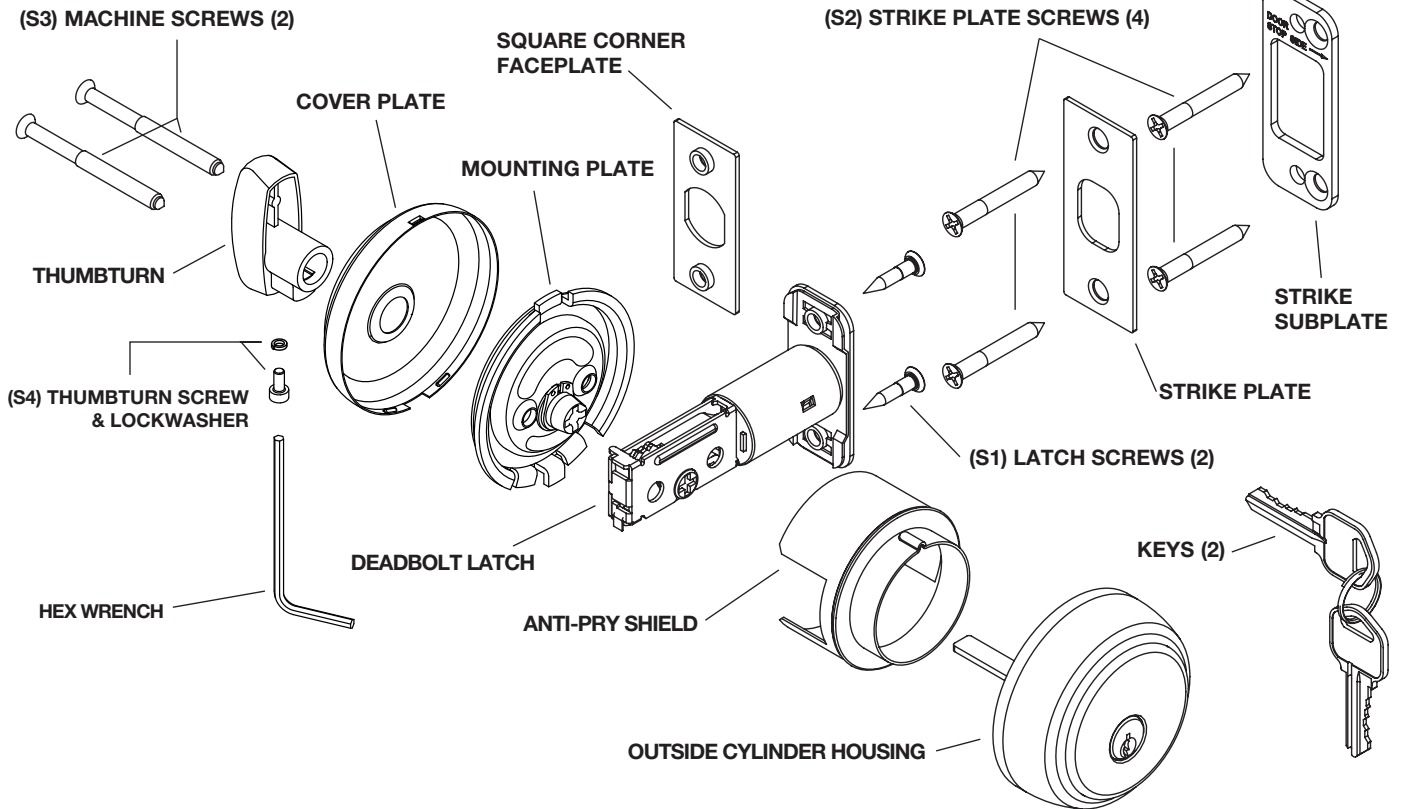

• FITS DOORS 1-3/8" (35 mm) TO 1-3/4" (45 mm) THICK •

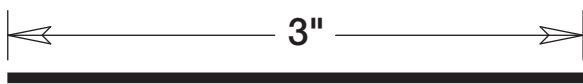

This line should be 3 inches. Measure it before using this template. If the line is not 3 inches when measured, print this instruction out, full scale on paper that is 8.5" x 11" and measure again.

TEMPLATE

Fold on dotted line and fit on door edge

Make a 1" (25.4mm) hole at center of door edge

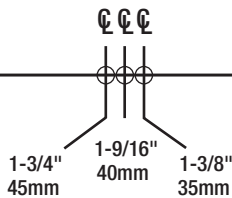

For backset 2-3/4" (70mm)

For backset 2-3/8" (60mm)

Fits 2-1/8" (54mm) cylinder hole

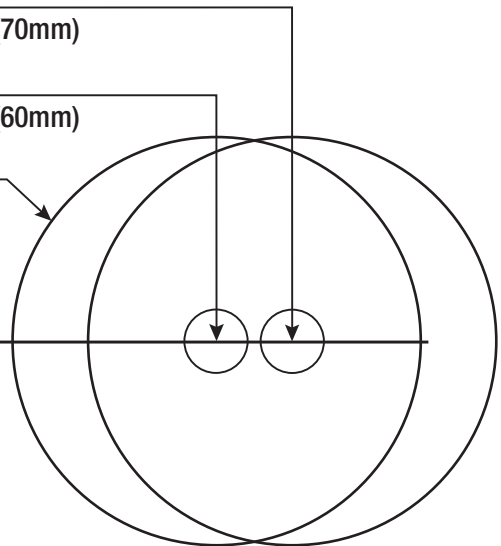

Instructions apply to the following styles:

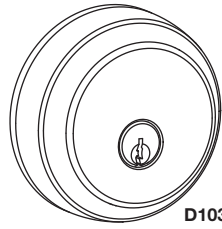

D103-1

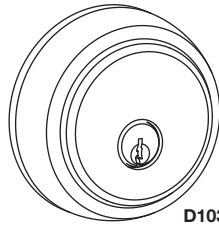

D103-2

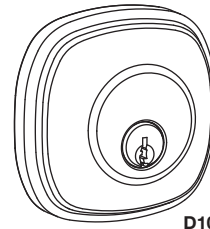

D103-3

For Replacement Installation Instructions: Remove existing deadbolt, deadbolt latch and strike plate and begin at Step 4. **For New Installation Instructions:** Begin at Step 1.

STEP 1 Mark Door with Template

- Mark the centerline for the deadbolt about 44" (1120 mm) from the floor, or about 5-1/2" (140 mm) above the center of an existing knob or lever.
- Apply the template to the door with the dotted fold line on the door edge.
- Select the 2-3/8" (60 mm) or 2-3/4" (70 mm) backset and mark the center for the hole for the deadbolt on the door face. (Most residential doors have a 2-3/8" backset.)
- Mark the center for the latch hole on the door edge according to the thickness of your door.

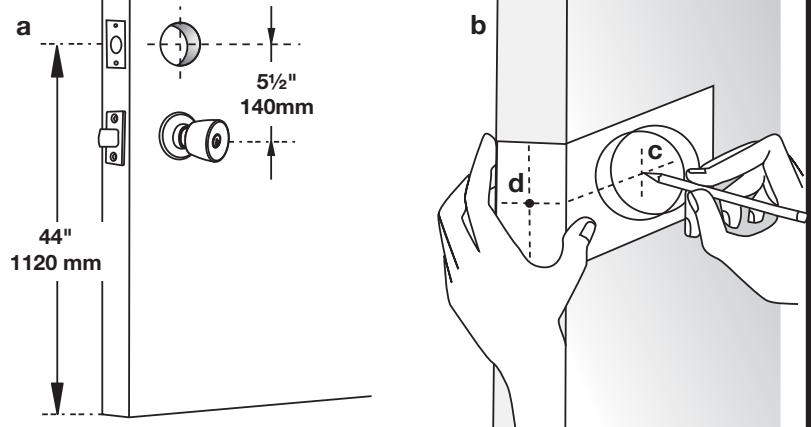

STEP 2 Drill Holes

- Drill a 2-1/8" (54 mm) hole on the door face from both sides to avoid wood splitting.
- Drill a 1" (25.4 mm) hole in the door edge for the latch.
- Insert latch into hole, mark outline of faceplate, and chisel 1/8" (3 mm) deep or until the faceplate is flush with the door edge.
- Mark latch screw holes and drill two 1/8" (3 mm) pilot holes for the Latch Screws.

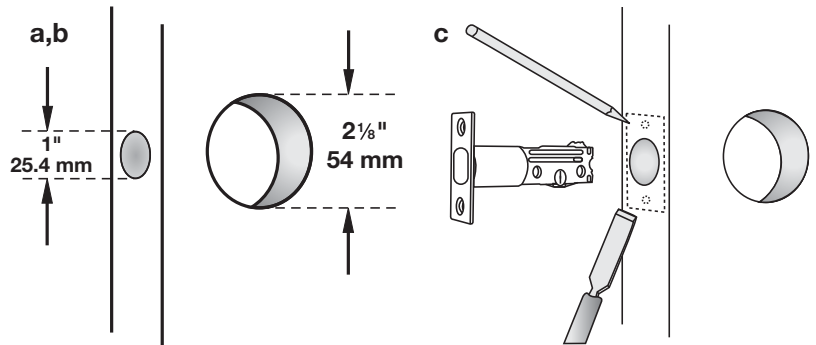

STEP 3 Prepare Door Jamb for Strike Plate

- Mark centerline on the door jamb exactly opposite the latch hole in the door edge. Make sure that the mark is correct so that the latch bolt will enter the strike plate without interference when the deadbolt is locked.
- Drill a 1" (25.4 mm) hole at least 1-1/8" (29 mm) deep in the door jamb.
- Center the Strike Plate over the 1" hole and mark the outline. Chisel about 7/32" (5.5 mm) deep or until Strike Plate and Subplate are flush with door jamb.
- Place the Strike Subplate in the prepared area in the door jamb with the words "DOOR STOP SIDE---->" visible and pointing towards the door jamb. Mark the 4 hole locations for the screws. Remove the Strike Subplate.
- Drill four 1/8" (3mm) pilot holes 1-1/2" (38mm) deep.
- See Step 8 for Strike Subplate and Strike Plate installation.

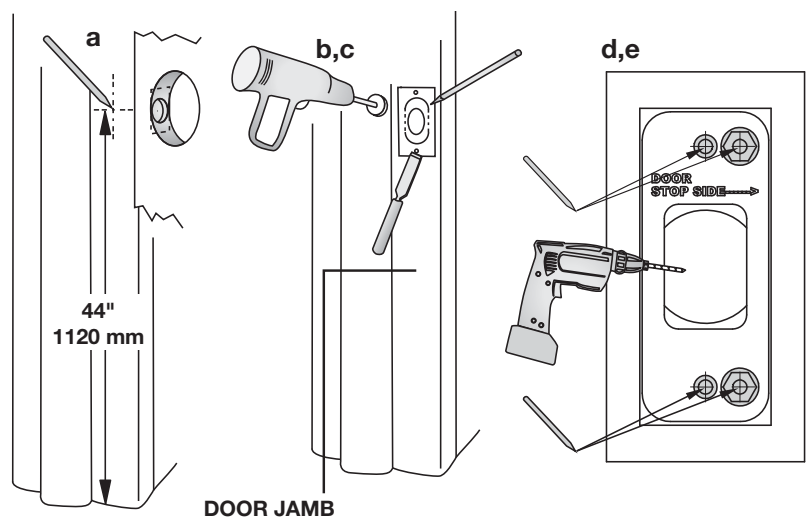

STEP 4 Selecting the Proper Backset

Backset is the distance from door edge to center of hole on door face. (See Illustration) The latch can be adjusted to fit either a 2-3/8" (60 mm) or a 2-3/4" (70 mm) backset. The latch is set at a 2-3/8" backset from the factory.

To adjust the backset from 2-3/8" to 2-3/4":

- Retract the latch bolt.
- Hold the Latch Faceplate in the left hand and the Latch Tail in the right hand.
- Twist the Latch Faceplate clockwise (towards you) about 1/8 turn.
- Pull the Latch Faceplate out towards the left until it stops.
- Rotate counterclockwise back into position so that the locking notch is engaged in the hole marked 2-3/4".

To adjust the backset from 2-3/4" to 2-3/8":

- Retract the latch bolt.
- Hold the Latch Faceplate in the left hand and the Latch Tail in the right hand.
- Twist the Latch Faceplate clockwise (towards you) about 1/8 turn.
- While pressing on end of bolt, push the Latch Faceplate in towards the right until it stops.
- Rotate counterclockwise back into position so that the locking notch is engaged in the hole marked 2-3/8".

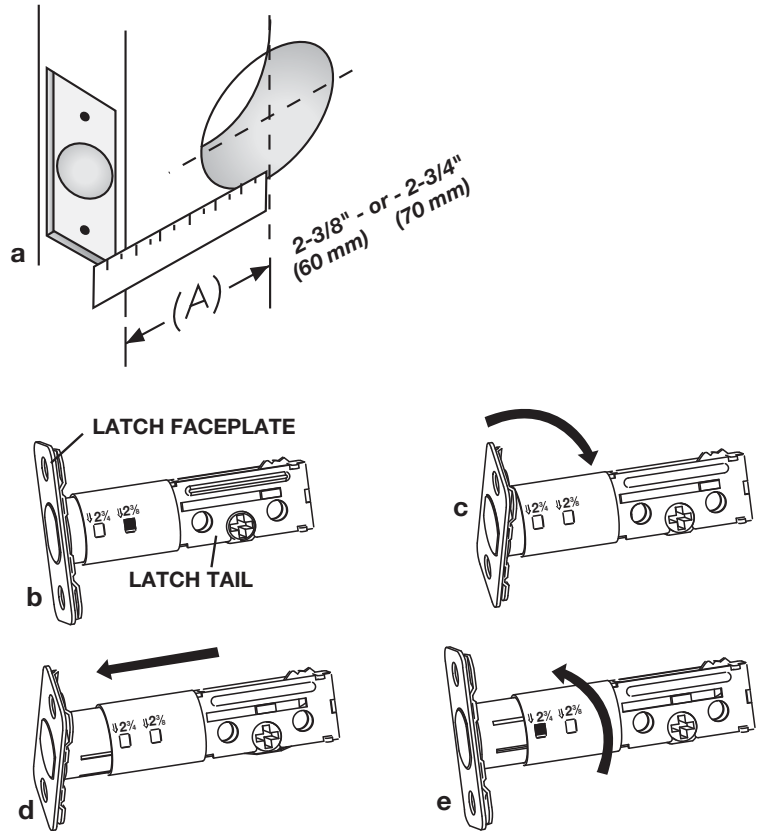

STEP 5 Install Latch

- Select appropriate faceplate (square or round corners) to match the cutout in the door edge.
- To change the faceplate, carefully separate the faceplate from the latch using a flathead screwdriver. Align and "snap" on the desired faceplate.
- Install latch into the hole in the edge of the door in the "UP" position as marked on the latch with the "cross" shaped crank at the bottom.
- Insert two (S1) Latch Screws through the holes in the faceplate and tighten firmly.

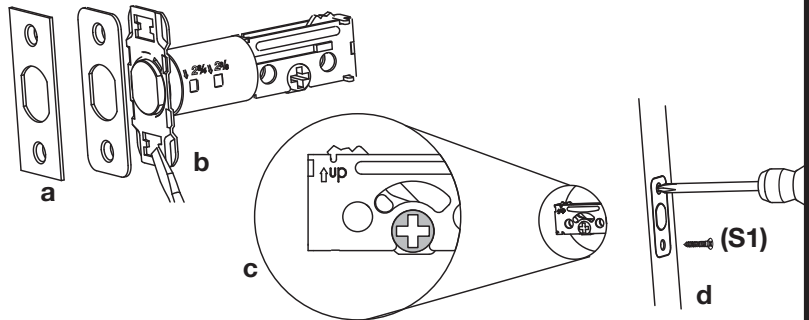

STEP 6 Install Outside Cylinder Housing

- Orient the torque blade of the cylinder in a horizontal position. Make sure that the bolt of the Deadbolt Latch is retracted. Keyhole should be in the down position.
- Insert the torque blade through the "cross" shaped crank of the Deadbolt Latch and push the Outside Cylinder Housing until it is flush with the door.
- If the existing hole in the door is less than 2-1/8" (54 mm) in diameter, the Anti-Pry Shield may not fit. To utilize all of the security features of the Deadbolt, it is recommended to open the hole diameter and install the complete Outside Cylinder Assembly with the Anti-Pry Shield.
- However, the Anti-Pry Shield can be removed to accommodate a smaller hole in the door. Simply pull the Anti-Pry Shield out of its groove in the Outside Cylinder Assembly.

NOTE: Removal of the Anti-Pry Shield will not affect the function of the deadbolt, but it does reduce the strength and resistance to prying attacks. The Deadbolt will no longer meet ANSI Grade 2 standards.

NOTE: IT IS IMPORTANT THAT THE TORQUE BLADE IS INSERTED HORIZONTALLY IN THE CROSS-SHAPED CRANK OF THE DEADBOLT LATCH FOR PROPER TIMING.

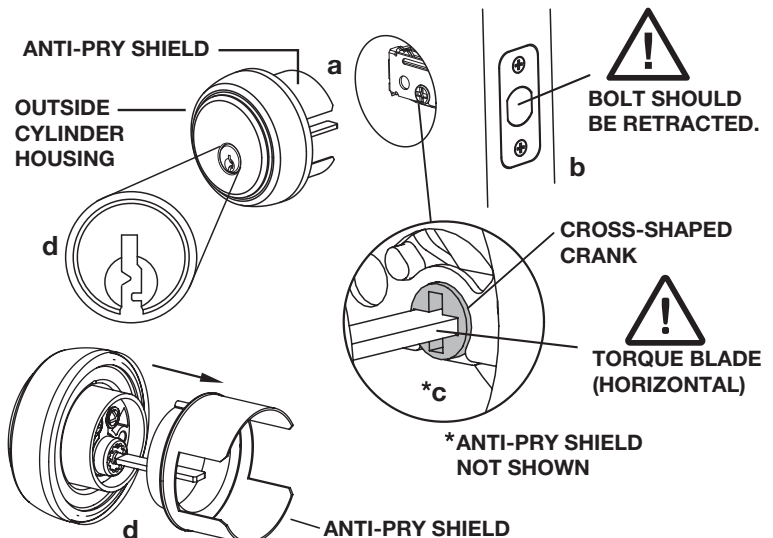

STEP 7 Install Thumbturn Assembly

- First, remove the Thumbturn by loosening the (S4) Thumbturn Screw & Lockwasher using the supplied Hex Wrench (there is no need to remove the screw completely) and slide the Thumbturn off the Spindle.
- Remove the snap-on Cover Plate by inserting a flathead screwdriver into the slot in the bottom and rotating to separate the Cover Plate from the Mounting Plate.
- Slide the Mounting Plate onto the Torque Blade and push until it is flush against the door. Insert the two (S3) machine screws through the holes in the Mounting Plate, engaging the threaded holes in the Outside Cylinder Assembly and tighten firmly. Snap the Rose onto the Mounting Plate.
- Align the Thumbturn with the Spindle. The shape of the Spindle allows the Thumbturn to be assembled in only one orientation.
- Slide the Thumbturn onto the Spindle, and tighten the (S4) Thumbturn Screw & Lockwasher using the Hex Wrench. The Thumbturn Screw should engage the hole in the Spindle. Tighten firmly until the head of the screw is flush with the thumbturn.
- Test the installation by extending the bolt using the Thumbturn, and by retracting the bolt using your key in the Outside Cylinder Assembly.

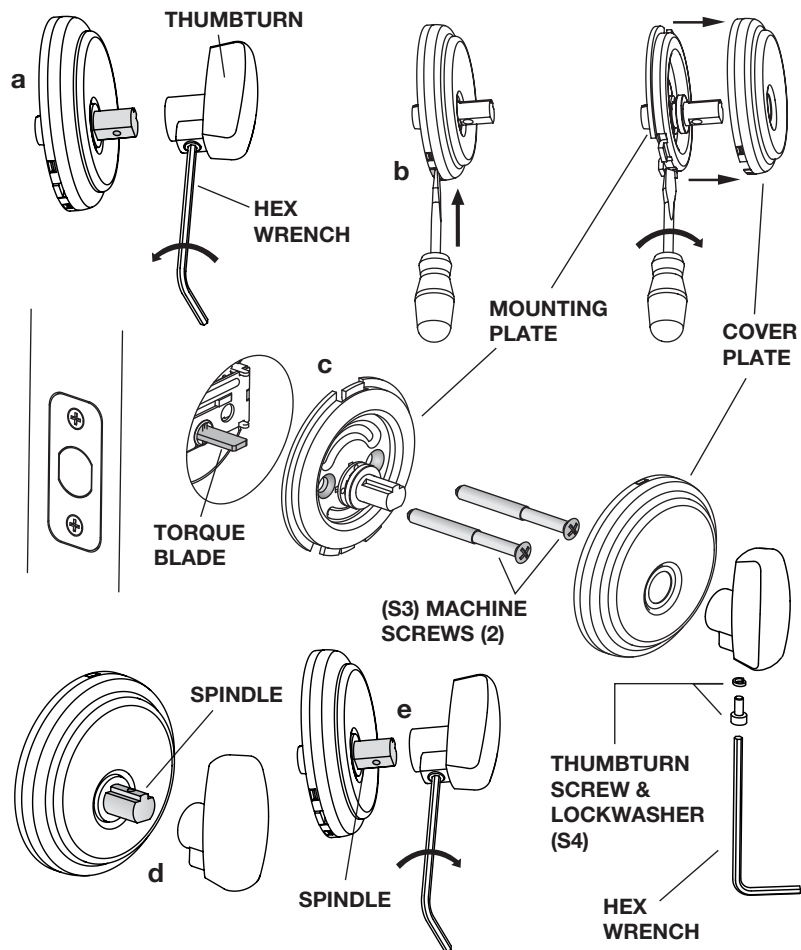

STEP 8 Install Strike Plate with Strike Subplate

- Place the Strike Subplate in the prepared area in the door jamb with the words "DOOR STOP SIDE---->" visible and pointing towards the door jamb. Make sure that the Subplate is positioned to receive the bolt from the Deadbolt Latch when extended.
- Insert two (S2) Strike Plate Screws through the holes in the Subplate and tighten firmly.
- Place the Strike Plate over the Subplate and insert two (S2) Strike Plate Screws through the holes in the Strike Plate. Tighten firmly.
- Close the door and test by extending the bolt using the Thumbturn. Make sure that the bolt can be inserted fully into the Strike Plate.

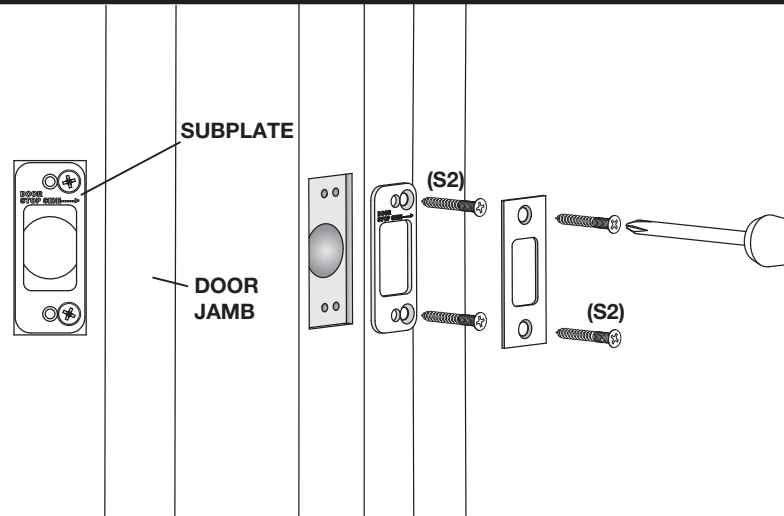

FULL LIFETIME WARRANTY - This product is fully warranted to be free of defects in material and workmanship for the life of the product. If a defect in material or workmanship occurs, call 800-562-5625 for instructions on how to have it replaced or repaired free of charge. This warranty is null and void if the product was used for purposes for which it was not designed, is abused, misused, modified or improperly installed, operated, maintained, and/or repaired. NOT LIABLE FOR INCIDENTAL, INDIRECT, OR CONSEQUENTIAL DAMAGES. Some states do not allow the exclusion or limitation of incidental or consequential damages, so the above limitation or exclusion may not apply to you. This warranty gives you specific rights, and you may also have other rights that vary from state to state.



Brink's trademark & copyright works are used with permission.

999-00317E_EN

Hampton Products International Corp.
50 Icon, Foothill Ranch, CA 92610-3000 USA
www.hamptonproducts.com 1-800-562-5625
www.brinksprr.com

©2015 Hampton Products International Corp.
999-00317E_EN_REV B 11/15